



**X75-2** Armchair  
Design: Børge Lindau & Bo Lindekrantz, 1972



## A CLASSIC TRUE TO ANY ERA

Lammhults' early collaboration with the designers Börge Lindau and Bo Lindekrantz lead to many successful products. The second product group, named X75, was introduced in 1972. Many of the pieces could be folded, such as the timeless X75-2, with steel tube frame and canvas seat and back. The practical nature of folding furniture which allowed more compact living became an embellishment to the playful stylistic nature of the Lindau-Lindekrantz design

The combination of design and engineering was so unusual that X75-2 was quickly recognized as trailblazing. X75-2 comes with a seat and back in canvas, the seat with reinforcements in matching leather. The frame comes in powder coated or chromium plated steel tubing. The cross tubing is always powder coated in black



X75-2



ARMCHAIR



**LAMMHULTS**

## SPECIFICATIONS

### ARMCHAIR

Foldable frame of 25 mm chromium plated or powder coated steel tubing.  
Cross tubing always powder coated in black. Upholstery in black canvas alt.  
natural linen. Seat with reinforcements in matching leather.

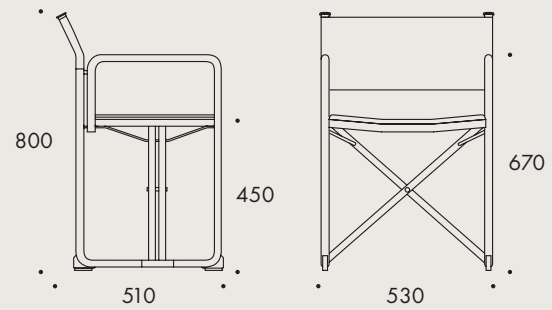

WEIGHT  
Armchair

7.9 kg



**OPTIONS**

COLORS  
UPHOLSTERY



Black

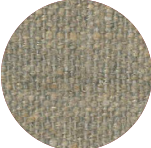

Natural



**LAMMHULTS**



## **LAMMHULTS**

Lammhults Möbel AB

Box 26  
SE-363 03 Lammhult  
Sweden

+46 472 26 95 00  
info@lammhults.se  
lammhults.se